

- 1 Attach bracket (including mounted AcquaSaver) to wall.
- 2 Install pump in rainwater tank.
- 3 Install piping from pump to AcquaSaver
- 4 Connect mains supply to AcquaSaver.
- 5 Connect AcquaSaver 'To House' supply.
- 6 Plug pump electrical cable into wall electrical socket.

RECOMMENDATIONS

- Do not install unit behind the rainwater tank. Install to left of rainwater tank where possible.
- Install pump with barrel union connection (not supplied) inside the top of the rainwater tank (for future removal of pump).
- Install ball valve (not supplied) on mains supply to AcquaSaver (for future maintenance).

COMMISSIONING

- 1 Turn electrical power off to the pump (house will be supplied by mains water).
- 2 Open mains water ball valve.
- 3 Flush Toilet to test mains water.

If water available in rainwater tank

- 1 Turn on electrical power and pump will start.
- 2 Flush toilet to test pump. Listen to ensure pump is working.

PREFERRED INSTALLATION – LEFT OF TANK

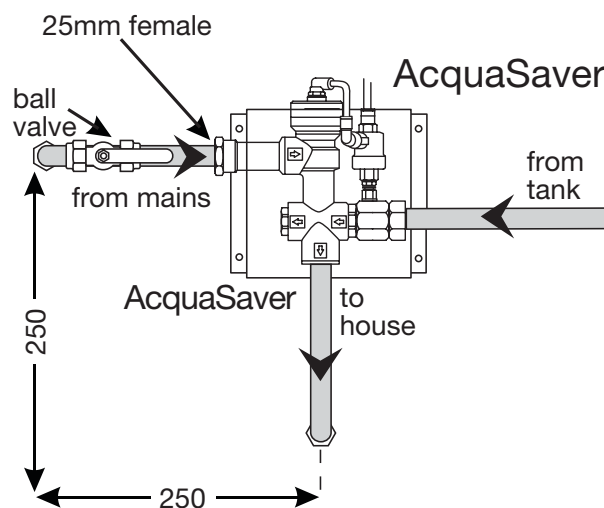
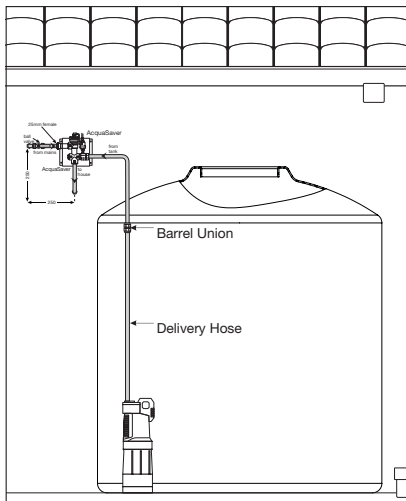

INSTALL RIGHT OF TANK

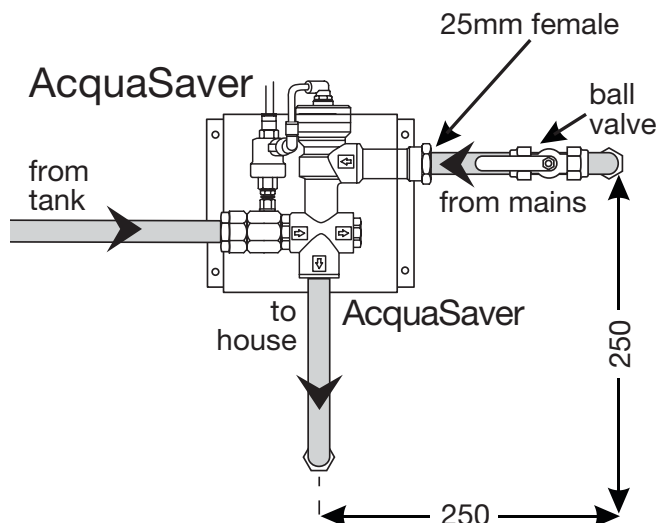
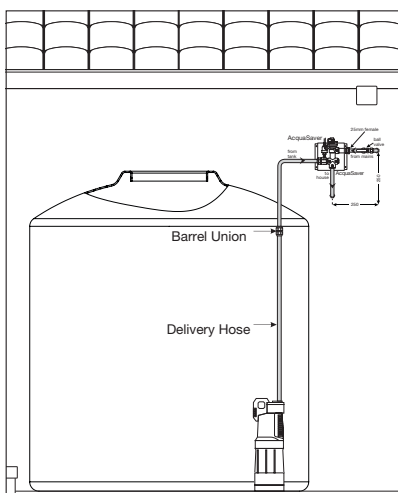

Rainwater Management Systems with Hydraulic Mains Switching



Laundry/Toilet – LMS3A

- ✓ Suitable for domestic toilets and washing machine connections

Includes: pump and mains diverter
Note: product available including pump base and cover

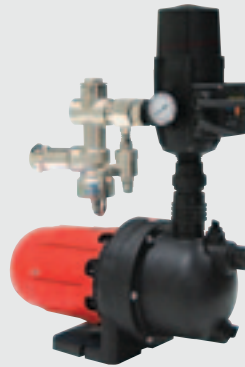

3 x

Power
700 w

Max. head
42 metres

Max. flow rate
50 l/min

Laundry/Toilet/Garden – LMS7A

- ✓ Suitable for domestic toilets, washing machine & external garden taps

Includes: pump and mains diverter



4 x

Power
800 w

Max. head
42 metres

Max. flow rate
60 l/min

Laundry/Toilet/Garden/Household – LMS5A

- ✓ Suitable for domestic toilets, washing machine & external garden taps
- ✓ Water supply to complete household
- ✓ Quiet Running

Includes: pump, wall bracket and mains diverter



8 x

Power
1000 w

Max. head
48 metres

Max. flow rate
100 l/min

Laundry/Toilet/Garden/Household – LMS6A

- ✓ Suitable for domestic toilets, washing machine & external garden taps
- ✓ Water supply to complete household
- ✓ Silent Running

Includes: pump, wall bracket and mains diverter



7 x

Power
1100 w

Max. head
48 metres

Max. flow rate
95 l/min

- Manufactured to Australian Standards
- Designed by the world leaders in pumping technology
- Tested & ready for use
- Hydraulic operated does not require power